

Bentley
Advancing Infrastructure

 CONNECT Edition



OpenPlant Modeler

Work Remotely or Connected with Support for Multiple Formats and Data Types

OpenPlant Modeler is an accurate, rapid, design engineering solution for 3D plant design. It enhances project teams with mobile information, via ISO 15926, iModels, and support for multiple formats and data types, such as DGN, DWG, JT, point clouds, and PDF to provide flexible design and review processes. OpenPlant Modeler is the right software for any project, large or small.

The CONNECT Edition

The SELECT® CONNECT Edition includes SELECT CONNECT services, new Azure-based services that provide comprehensive learning, mobility, and collaboration benefits to every Bentley application subscriber. Adaptive Learning Services helps users master use of Bentley applications through CONNECT Advisor, a new in-application service that provides contextual and personalized learning. Personal Mobility Services provides unlimited access to Bentley apps, ensuring users have access to the right project information when and where they need it. ProjectWise® Connection Services allow users to securely share application and project information, to manage and resolve issues, and to create, send, and receive transmittals, submittals, and RFIs.

Interoperability Through Use of ISO 15926 as Intrinsic Data Model

OpenPlant Modeler is the first plant design software to use ISO 15926 as its intrinsic data model. The result is a significantly improved ability to dynamically exchange information among OpenPlant and other plant design software, supplier databases, and any applications using ISO 15926, without the need to communicate through proprietary interfaces.

Easy Reuse of Standards Facilitates Projects

Existing designs, models, and associated data, as well as catalogs and specifications from PDS, AutoPLANT®, and PlantSpace® can be easily reused, enabling faster project start-ups and design continuity. Existing PDS designs can be reviewed and augmented through ISO 15926 protocols or iModels to avoid proprietary lock-in.

Specification-driven Modeling Improves Designer Workflows

OpenPlant Modeler is a specification-driven modeling system that matches how a designer works. Designers can rapidly and easily create 3D models using the highly intuitive MicroStation® task-based user interface.

Multi-practitioner Support Provides Integrated Design

OpenPlant Modeler includes design functionality for piping, equipment, supports, instrumentation, HVAC, and other components to ensure projects deliver integrated design models. You can increase project collaboration with building design through the ability to define common gridlines across OpenPlant Modeler and AECOSim Building Designer. Moreover, you can accelerate projects through shared structural components across OpenPlant Modeler and OpenPlant Support Engineering.

Point Clouds Integrated with 3D Models Support Real-world Projects

Point clouds are a very useful way to visualize existing facilities or geospatial requirements. Through Descartes, OpenPlant Modeler integrates point clouds into 3D models to be used for retrofit design, providing a high level of accuracy, safety, and speed that reduces time to construction and eliminates field rework.

Reality Modeling with Context Capture and LumenRT Supports Brownfield Projects

OpenPlant Modeler makes it easier to work on brownfield projects by integrating with context capture reality models generated through digital photographs capturing existing condition. Reality visualization capabilities provide realistic data for reviews, project HAZOP and progress meetings.

Easily Check P&IDs and 3D Models for Consistency to Improve Design Accuracy

OpenPlant Modeler reads OpenPlant PID supplied P&IDs, leveraging existing information to speed 3D design. This also enables consistency checking to help ensure that 3D models match the requirements of the critical P&ID documents needed for contractual and regulatory compliance.

Increase Project Collaboration

The software increases project team collaboration with an environment that supports users working either stand alone or synchronized to the rest of the team in a distributed environment. Through the use of ProjectWise, OpenPlant Modeler users can participate in a globally dispersed project and be supported in a federated workflow. There is no need to replicate databases locally, or to always be connected.

OpenPlant Modeler allows users to improve collaboration, personal productivity, and information sharing by signing in as a Connected User and associating files with Connected Projects. Connected Users can access personalized learning, communities, notifications, and project information. Connected Projects provide project level reporting including which Connected Users are working a project, how much time they are spending on a project, and what Bentley applications they are using. Get access to CONNECT Edition applications that can be leveraged to improve team collaboration and manage field data.

Reduce Costs by Reading Piping Specifications in Multiple Formats

In addition to working with OpenPlant's own catalog and specification capabilities, OpenPlant Modeler can directly read piping catalogs and specifications from PDS, AutoPLANT, and PlantSpace, speeding project start-up and reducing administration and checking costs.

System Requirements

Operating System

Windows 10, 8.1, 8, 7 SP1 (64-bit),
Windows Server 2012/2008

Software Prerequisites

Microsoft .NET Framework 4.6.2,
Microsoft Visual Basic for Applications
core, Microsoft Visual Basic for
Applications localized, Microsoft
Internet Explorer, minimum v11.0,
with 128-bit cipher strength. Microsoft
no longer supports any versions
prior to v11.0. Internet Explorer is
not installed as part of the product
pre-requisites.

Processor

Intel or AMD processor 1.0 GHz
or greater. OpenPlant PID is not
supported on a CPU that does not
support SSE2.

Memory

4 GB minimum, 16 GB recommended

Disk Space

12 GB minimum, 12-22 GB
depending additional installations
such as Companion Feature and
Companion Product.

Graphics Card

See the graphics card manufacturer
for latest information on DirectX
drivers. 512 MB of video RAM or
higher is recommended. If insufficient
video RAM or no graphics card
supported by DirectX can be found,
OpenPlant PID attempts to use
software emulation. For optimal
performance, graphics display
color depth should be set to 24-bit
or higher. When using a color depth
setting of 16-bit, some inconsistencies
will be noted.

**Find out about Bentley
at: www.bentley.com**

Contact Bentley

1-800-BENTLEY (1-800-236-8539)
Outside the US +1 610-458-5000

Global Office Listings

www.bentley.com/contact

Bentley
Advancing Infrastructure

OpenPlant Modeler At-A-Glance

Open Data Model

- Uses ISO 15926 as the intrinsic data model
- Exchange data among applications using iModels
- Industry-leading interoperability
- Reference in iModels from heterogeneous systems including PDS, SP3D, and PDMS, to create complete plant models
- Publish plant models via iModels to Navigator for clash resolution, and ConstructSim for construction simulation and WorkFace Planning
- Export to a wide range of formats such as DGN, DWG, DXF, IGES, CGM, STL, SVG, OBJ, U3D, and many more
- Import to formats including IGES, Parasolids, ACIS SAT, CGM, Step AP203/AP214, STL, Terrain Model Land XML, and CAD files

Ease of Use

- Leverages powerful MicroStation graphical user interface capabilities
- New streamlined and intuitive ribbon interface
- Provides for automatic data validation and connectivity
- Allows quick and easy copying of reusable design information
- Enables faster and more intelligent editing and modification of designs

Reality Modeling Support

- Reference point clouds directly in 3D models
- Interact with point clouds using Descartes within OpenPlant Modeler

Reuseable Catalogs and Specifications

- Take advantage of support for EN, DIN, and other enhanced catalogs to support European design standards
- Create piping specifications from scratch or by editing example specifications
- Access AWWA standard fittings to speed water/wastewater projects
- Access Lindab standard HVAC components
- Import specifications from AutoPLANT, PlantSpace Design

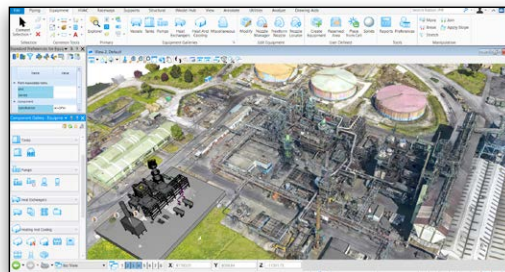

Details of components can be easily seen in a grid view.

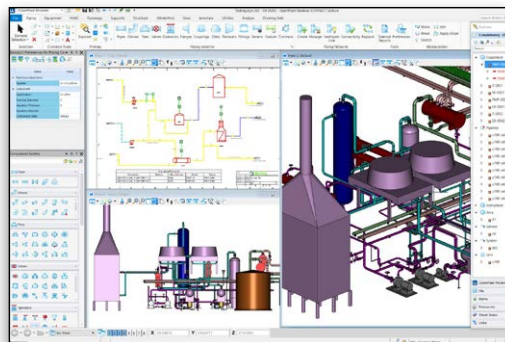

2D/3D model integration enhances project accuracy.

Series, or PDS

- Define automatic bend, flange, and branch selections

Component Features

- Task-based menu that groups like components together (piping, equipment, cable tray)
- Element manipulators that provide easy editing
- Automatic placement of fittings
- Alignment to intersection with other components
- Ability to insert from any point on a component (such as branch, center, or run of a tee)
- Ability to change size and or specification of individual components or entire line

Project Workspaces

- Shares centrally managed catalogs and specifications
- Leverage Connected Projects, workspaces and workset concepts

Material Reporting

- Enables powerful queries that allow selection by any property or field
- New reporting capability with easy to customize interface
- Ability to define reports via OpenPlant Project Administrator

Clash Detection

- Provides the ability to run clash detection in the active design session

Publish Design Files to ProjectWise Share

- Exchange files of any size quickly through a centralized, easy-to-use platform
- Allow designated project participants to easily access project deliverables without opening your firewall
- Discover up-to-date files readily by organizing them in an intuitive, project-based context
- Reduce disruptions to your workflows via integration with other select Bentley design applications

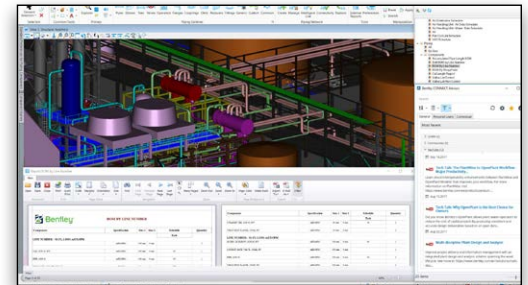

The Model Component browser provides a concise breakdown of the contents of the model repository.

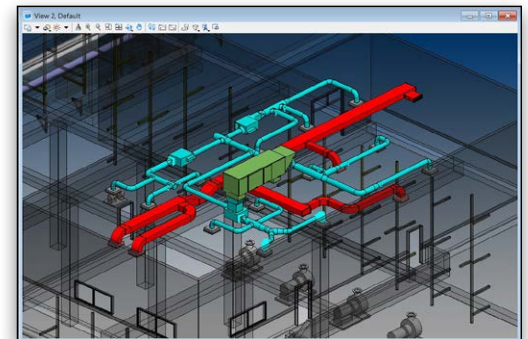

HVAC components are integrated with piping for robust plant design.